

000014416001 HALL CURTIS A & CARRIE BASINGER (1/2) 108 SIXTH AVE

ADMINISTRATIVE INFORMATION

OWNERSHIP

Tax ID 54- 57

Printed 08/05/2021

PARCEL NUMBER
000014416001

HALL CURTIS A & CARRIE BASINGER (1/2)
G LINCOLN HALL ESTATE
3031 W VOGEL AVENUE
GREENFIELD WI 53221

TRANSFER OF OWNERSHIP

Parent Parcel Number

6TH AVE
70 FT FRONTAGE
OLD ACCT#: 1291

Date
05/09/2018 HALL DIXIE C REVOCABLE TRUST &
06/25/2012 HALL G ALLEN ESTATE & MARY M
11/14/2011 HALL G ALLEN & MARY M

Bk/Pg: 618, 727
\$0
Bk/Pg: 550, 337
\$0
Bk/Pg: CWF, 11-126
\$0

Property Address
108 SIXTH AVE

Neighborhood
1 Galax

RESIDENTIAL

Property Class
1 1 SINGLE FAMILY - URBAN

VALUATION RECORD

Assessment Year	01/01/2000	01/01/2004	01/01/2008	01/01/2012	01/01/2016	01/01/2020		
Reason for Change								
	Split	2004 Reass.	REVAL	2012 REVAL	2016	2020 REVAL		
VALUATION	L	5000	7000	8000	7500	7500	9000	
	0	B	22900	34100	43700	42600	38800	41800
		T	27900	41100	51700	50100	46300	50800

TAXING DISTRICT INFORMATION

Jurisdiction 231
Area 001
District 01

Site Description

LAND DATA AND CALCULATIONS

Topography:	Rating	Measured	Table	Prod. Factor						
Rolling	Soil ID	Acres		--or--						
Public Utilities:	--or--	Effective	Effective	Depth Factor						
Electric, Sewer, Water	Actual	Frontage	Depth	--or--	Base	Adjusted	Extended	Influence		Value
	Frontage	Frontage	Depth	Square Feet	Rate	Rate	Value	Factor		
1 Homesite					1.00	9000.00	9000.00	9000	SV	9000

Street or Road:
Paved

Neighborhood:

Zoning:

Legal Acres:

OMAP: 04- 49
REPLACEMENT WINDOWS

Supplemental Cards

Supplemental Cards

MEASURED ACREAGE

0.0000

TRUE TAX VALUE

9000

Supplemental Cards

TOTAL LAND VALUE

9000

IMPROVEMENT DATA

000014416001

Property Class: 1
108 SIXTH AVE

PHYSICAL CHARACTERISTICS

Style: 109 Cape cod
Occupancy: Single family
Story Height: 1.3
Finished Area: 1296
Attic: None
Basement: Full

ROOFING

Material: Asphalt shingles
Type: Gable
Framing: Std for class
Pitch: Not Available

FLOORING

Slab B
Sub and joists 1.0, 1.5
Carpet B, 1.0, 1.5

EXTERIOR COVER

Cinder block B
Vinyl siding 1.0, 1.5

INTERIOR FINISH

Plaster B, 1.0, 1.5

ACCOMODATIONS

Finished Rooms: 6
Bedrooms: 3
Fireplaces:

HEATING AND AIR CONDITIONING

Primary Heat: Forced hot air
Lower Full Part
/Bsmt 1 Upper Upper

PLUMBING

	#	
3 Fixt. Baths	1	3
Kit Sink	1	1
Water Heat	1	1
TOTAL		5

REMODELING AND MODERIZATION

Amount Date

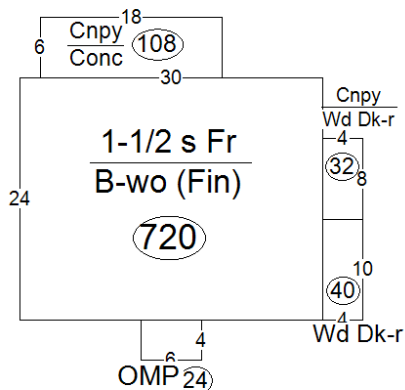

01

02



(LCM: Something goes here)

SPECIAL FEATURES

Description	Value
D : SWL-PWS	2500

SUMMARY OF IMPROVEMENTS

ID	Use	Stry Hgt	Const Type	Grade	Year Constr	Eff Year	Cond	Base Rate	Feat-ures	Adj Rate	Size or Area	Computed Value	Phys Depr	Obsol Depr	Market Adj	% Comp	Value
D	DWELL	0.00		C-10	1948	1948	F	0.00	Y	0.00	0	65530	45	42	0	100	41100
01	FR SHED	0.00	1	C	1970	1970	F	0.00	N	1.00	8x 8	60	0	0	SV	100	100
02	CC DRIVE	0.00	1	C	1970	1970	AV	0.00	N	0.00	14x 23	0	0	0	SV	100	600

Data Collector/Date	Appraiser/Date	Neighborhood	Supplemental Cards	TOTAL IMPROVEMENT VALUE
EE 07/17/2019	GE 07/17/2019	Neigh 1 AV		41800